

**VFL2-Ex, VTL2-Ex and VRA2-Ex**  
**Rectangular electric duct heaters**  
**for hazardous areas**



# VFL2-Ex, VTL2-Ex and VRA2-Ex

## Rectangular electric duct heaters for hazardous areas

VEAB's rectangular ATEX-approved duct heaters are available in ratings up to 1000 kW and are used for heating air in duct systems, central ventilation units and for various industrial processes in environments in which there occasionally occur danger of explosion (Zone 1 and Zone 2). Our flexible production enables us to adapt the duct heater to different sectors of application such as offshore, chemical industry, oil industry and ships.

- Power ratings from 1 kW to 1000 kW
- Temperature class T3 (max 200°C)
- For use in areas in which the dangers of explosion are due to gases or fumes (equipment category 2G)
- Degree of protection IP66
- Max. outlet temperature 40°C
- Ambient air temperature -50°C — 40°C
- Minimum air velocity 2.5 m/s
- Can be installed horizontally or vertically
- Built-in overheating protection and temperature limiter
- VFL2-Ex has heating elements mounted in a removable cassette



### Design

The casing is made of stainless steel EN 1.4301 or acid-resistant stainless steel EN 1.4404. The casing is available in four different versions. See page 7 for additional information. The duct heaters are produced to degree of protection IP66 in accordance with EN 60529.

The tubular heating elements are made of stainless steel, EN 1.4301 or from acid-resistant stainless steel, EN 1.4404, Incoloy 800 or Incoloy 825 on special request. The surface load is max 1 W/cm<sup>2</sup>. VFL2-Ex has heating elements mounted in a removable cassette. The magazine can be pulled out without dismantling the duct section.

The heaters are made with a junction box in Increased Safety Ex eb in compliance with EN 60079-7 and with overheating protectors and temperature limiter in Flame Proof Ex db performance and Ex mb Encapsulation in compliance with 60079-1.

There are Ex eb approved terminal blocks in the electric junction box for both heating elements, the overheating protection and the temperature limiter.

The duct heater has to be equipped with cable glands with IP66, or higher, protection approved for Ex eb or Ex db. These are not included in the delivery.

### Approvals

VEAB duct heaters fulfill the requirements within the ATEX directive 2014/34/EU.

VEAB quality system is certified by Intertek (NB 0359) according to certificate ITS12ATEXQ7607

Tests and certifications have been performed by Intertek (NB 0359) according to certificate ITS10ATEX36956X

Applied testing standards:

Degree of protection IP66, EN 60529

General ATEX requirements EN 60079-0

Ex e (increased safety) EN 60079-7

The heaters are also tested and approved by Intertek according to:

LVD directive: EN 60335-1 and EN 60335-2-30

EMC directive: EN 61000-6-3 and EN 61000-6-1

EMF directive: EN 62233

EAC Cert with Ex-annex



## Overheating protection/ Temperature limiter

All duct heaters have two manual overheating protectors for powerstep number 1, which limits the surface temperature of the heating elements to 200°C (temperature class T3).

When heat is required, power step 1 shall always be connected. When the duct heater has more than one power step, power step 1 shall always be the first to be energized when the heater is required for operation.

Power step 1 shall be the last to be switched off when the power is turned off.

In addition to this, there is also an automatic temperature limiter which limits the outgoing temperature. Resetting the manual overheating protectors is done inside the junction box.

The overheating protectors and the temperature limiter are constructed to break the security circuits if there is a leakage in the capillary tubes.

## Heater in the junction box

In order to further adapt the heater to your application there is a possibility to add a heater in the junction box. This is always recommended for damp environments and for outdoor installations in order to reduce the risk of condensation in the box at low temperatures. Please note that the heater is an option and not a standard delivery.

## Dimensions

ATEX-approved duct heaters are manufactured according to customer requirements. Width (B) and height (H) are chosen in accordance with the duct or the unit into which the heater is to be installed. The dimensioning has to reflect that the minimum air velocity through the heater is 2.5 m/s. Width and height have to be at least 200 mm and 3000 mm at the maximum, the depth has to measure at least 270 mm and it will be specified by VEAB at the time of quote or order.

## Markings

See page 5 for description.



**II 2 G Ex eb db mb IIC T3 Gb**

## Control

ATEX-approved duct heaters have to be controlled by appropriate control equipment that are approved for the specific environment in which the control equipment is placed. The control equipment must also have a separate sensor which automatically limits the temperature of the outgoing air from the heater to 40°C.

Observe local regulations governing control equipment for ATEX-certified duct heaters.

## Power supply

The voltage can be adjusted up to 690V3~ depending on customer requirements.

## Powersteps

The total output of the heater can be divided into a number of steps with maximum 63 A per step.

When more than one power step is used, it's recommended that the individual steps are of equal size.

## Circular connection

As a separate accessory for VFL2-Ex, an adapter to circular connection can be delivered. Dimension Ø100-800 mm.

### Installation

The duct heaters can be installed in horizontal or vertical ducts. The air flow through the duct heater must be in the direction of the arrow on the duct heater cover. In a horizontal duct system, the junction box may face either right, left or upwards. Installation with junction box facing downwards is not allowed. The duct heater must be mounted so that the air flow will be uniform throughout the cross-sectional area. We recommend that the distance to or from a duct bend, fan, damper, etc. should be at least the same as the diagonal dimension of the duct heater, i.e. from corner to corner at the connection face of the heater. In other cases, division plates must be fitted.

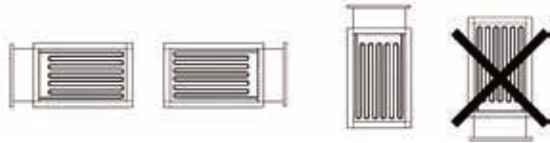

### Duct heaters with more than one powerstep

For duct heaters with more than one powerstep the overheating protectors are mounted on power step number 1. Power step 1 shall always be the first to be energized when the heater is required for operation and the last to be switched off when the power is turned off.

### Interlock with fan/air flow rate

Electric duct heaters must always be installed so that they are interlocked either with the fan that delivers air into the duct or with the air flow rate through the heater.

The power supply to the duct heater must be interrupted when the fan is tripped or if the air flow should cease. For heaters rated above 30 kW, it is recommended that the fan should be left running for at least 3 minutes after the power supply has been switched off.

### Minimum air velocity and outlet air temperature

The duct heaters are designed as standard for a minimum air velocity of 2.5 m/s and a maximum operating air temperature of 40°C.

Ambient temperature during operation is -50...+40°C.

The following formula can be used for calculating the air velocity:

$$V = \frac{Q}{3600 \times A}$$

$V$  = air velocity, m/s  
 $Q$  = air flow, m<sup>3</sup>/h  
 $A$  = cross-section of the duct heater (B×H), m<sup>2</sup>

### Power demand

The air flowing through the duct heater is heated in accordance with the following formula:

$$P = Q \times 0,36 \times \Delta t$$

$P$  = power, W  
 $Q$  = air flow, m<sup>3</sup>/h  
 $\Delta t$  = temperature rise, °C

### Air pressure drop across the duct heater

The pressure drop of the air flowing through the duct heater is dependent on the air velocity and the number of heating element rows in the heater. The approximate number of heating element rows can be calculated from the following formula:

$$X = \frac{P}{A \times 5}$$

$X$  = number of element rows  
 $A$  = flow area of the duct heater, B×H, m<sup>2</sup>  
 $P$  = total power, kW

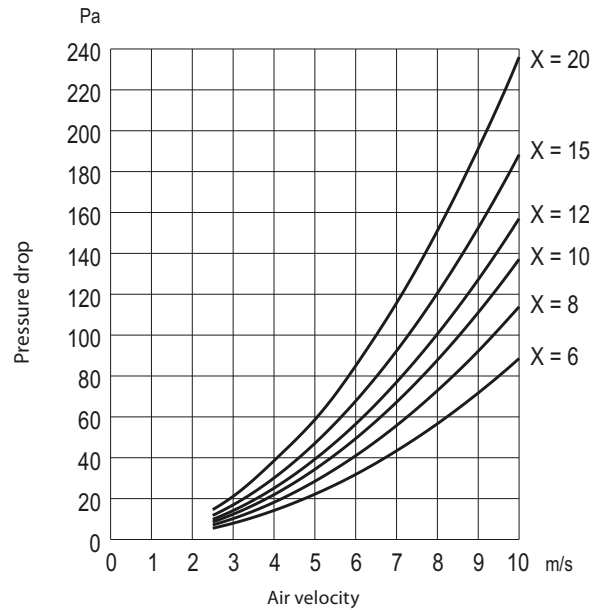



# II 2 G Ex eb db mb IIC T3 Gb

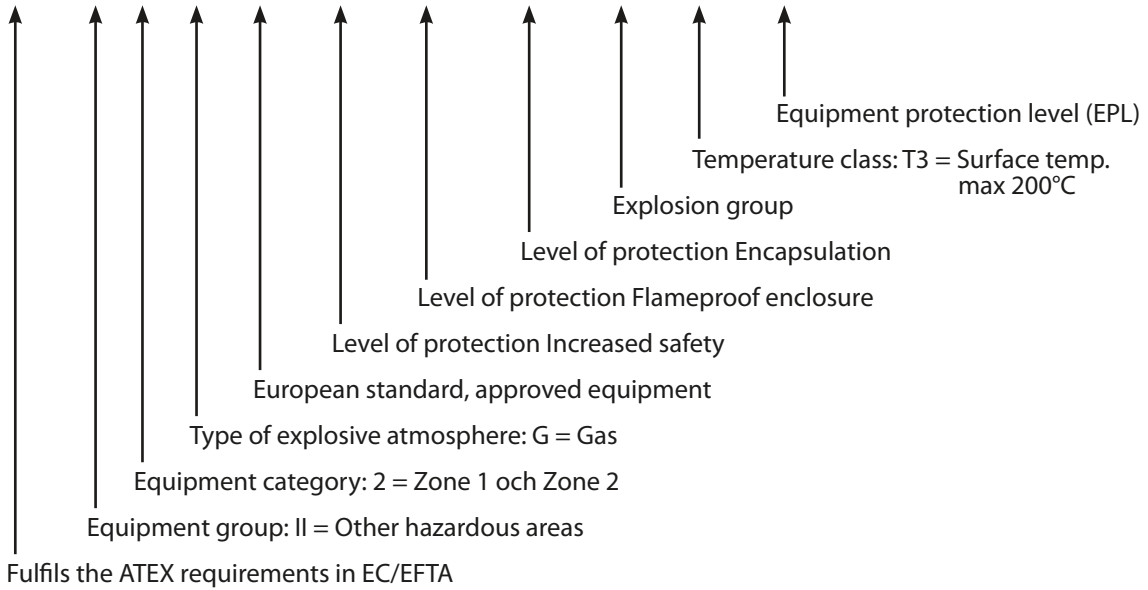

| Conditions in hazardous areas<br>(Subdivision regarding the probability, endurance and frequency of flammable gases and vapours) |  |   |
|--|--|---|
| Zone 2   | Zone 1                                 | Zone 0  |
| Not likely to occur, but if occurring only for short periods.  | Likely to occur but only occasionally. | Present continuously or for long periods or frequently. |
| Heaters can be used in   |  |   |
| 3 G  |  |   |
| 2 G (VEAB ATEX heater)   |  |   |
| 1 G  |  |   |

| Explosion group<br>(Subdivision regarding the gases and vapours according to their ignition energy) |                                     |                     |
|---|-------------------------------------|---------------------|
| IIA   | IIB                                 | IIC                 |
| Propane, Acetone, Benzene, Petroleum, Sporot, Diesel fuel   | Ethylene, Town gas, Ethylene glycol | Acetylene, Hydrogen |
| Heaters can be used in  |                                     |                     |
| IIA   |                                     |                     |
| IIB   |                                     |                     |
| IIC (VEAB ATEX heater)  |                                     |                     |

| Temperature class<br>(Subdivision regarding gases and vapours according to their ignition temperature) |        |        |        |        |       |
|--|--------|--------|--------|--------|-------|
| T1   | T2     | T3     | T4     | T5     | T6    |
| ≤450°C   | ≤300°C | ≤200°C | ≤135°C | ≤100°C | ≤85°C |
| Heaters can be used in   |        |        |        |        |       |
| T1   |        |        |        |        |       |
| T2   |        |        |        |        |       |
| T3 (VEAB ATEX heater)  |        |        |        |        |       |
| T4   |        |        |        |        |       |
| T5   |        |        |        |        |       |
| T6   |        |        |        |        |       |

## Dimensions

### VFL2 – with flanges

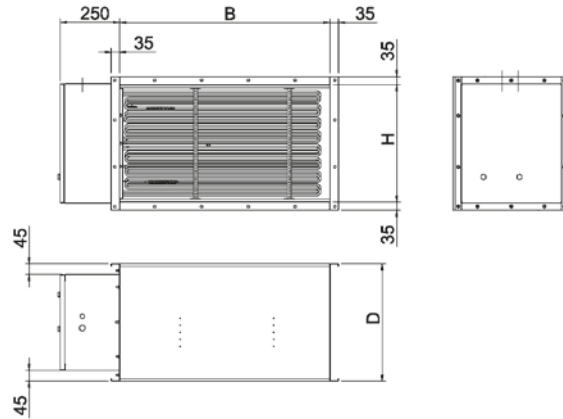
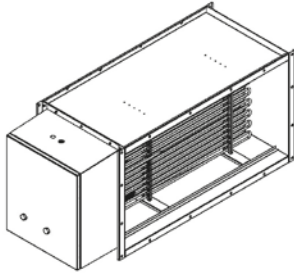

### VTL2 - for insertion mounting in duct system

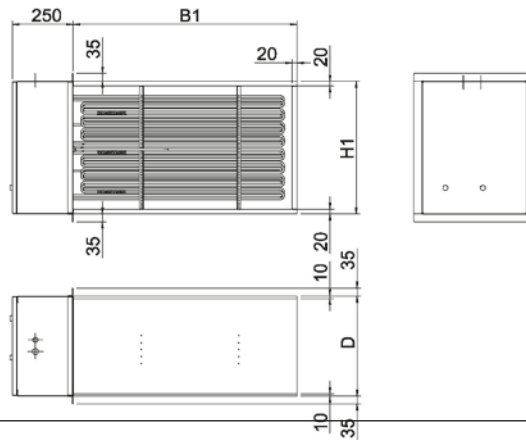
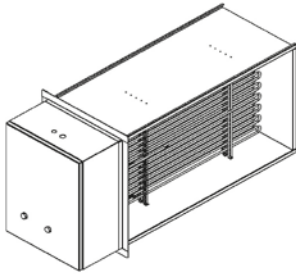

### VRA2 – for air handling units

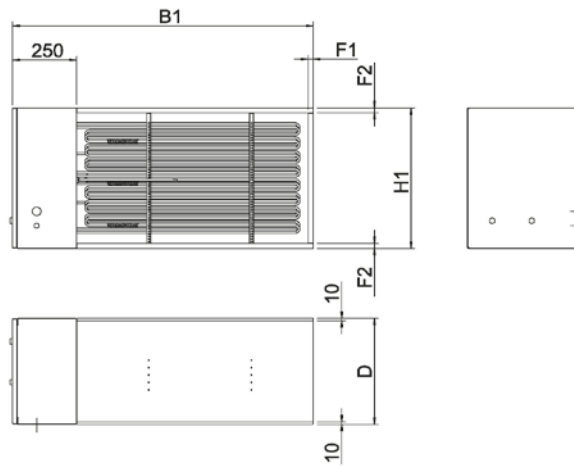
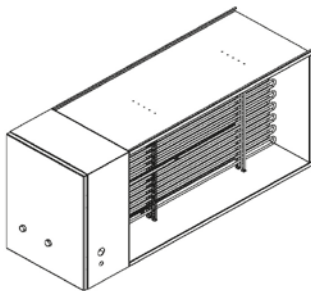

## Project design/orders

|   |   |
|---|---|
| Versions  | VFL2-Ex - Heater with flanges for mounting in duct<br>VTL2-Ex - Heater for insertion mounting in the duct<br>VRA2-Ex - Heater for air handling unit                           |
| Model   | M = Heater with built-in overheating protection and for external control equipment.   |
| Width, dimension B<br>Height, dimension H         | Min 200 mm. Max. 3000 mm (open area for air flow)<br>Min 200 mm. Max. 3000 mm (open area for air flow)  |
| Total output, kW                                  | Can be selected between 1 kW and 1000 kW  |
| Power supply voltage<br>/ max load / output stage | 1 × 230V = 1 phase 230V / 14,5 kW<br>2x 400 V / 25 kW<br>3x 230 V / 25 kW<br>3x 400 V / 43 kW<br>3x 440 V / 48 kW<br>3x 460 V / 50 kW<br>3x 500 V / 54 kW<br>3x 690 V / 75 kW |
| Casing material                                   | S = Stainless steel, EN 1.4301<br>SA = Acid-resistant stainless steel, EN 1.4404  |
| Degree of protection                              | IP66  |
| Electric insulation                               | NI = Normal electric insulation   |
| Temperature class                                 | T3 = Max 200°C on the surface of the heating elements   |
| Output temperature                                | 40C = 40°C max outlet temperature   |

### Type designation VFL2-Ex

A type designation of a duct heater may be, for example, VFL2-Ex-M-1200-500-80kW-3x400V-S-IP66-NI-T3-40C, which describes the design of the product. The type designation is made up in accordance with the following model:

| Versions | Model | Dimension<br>Width, B | Dimension<br>Height, H | Total output<br>kW | Power supply<br>voltage, V | Casing<br>material | Degree of<br>protection | Electric<br>insulation | Temperature<br>class | Output air<br>temperature |
|----------|-------|-----------------------|------------------------|--------------------|----------------------------|--------------------|-------------------------|------------------------|----------------------|---------------------------|
| VFL2-Ex  | M     | 1200                  | 500                    | 80 kW              | 3×400 V                    | S                  | IP66                    | NI                     | T3                   | 40C                       |

40+40

*No. of kW / step*

### Type designation VRA2-Ex and VTL2-Ex

| Versions | Model | Dimension<br>Width, B1 | Dimension<br>Height, H1 | Total output<br>kW | Power supply<br>voltage, V | Casing<br>material | Degree of<br>protection | Electric<br>insulation | Temperature<br>class | Output air<br>temperature |
|----------|-------|------------------------|-------------------------|--------------------|----------------------------|--------------------|-------------------------|------------------------|----------------------|---------------------------|
| VRA2-Ex  | M     | 1485                   | 570                     | 80 kW              | 3×400 V                    | S                  | IP66                    | NI                     | T3                   | 40C                       |

## Project design/orders

### Descriptive text - VFL2-Ex

ATEX-approved duct heater of VEAB type VFL2-Ex-1200x500-80kW-3x400V-M-S-IP66-T3-40C, with casing in stainless steel EN 1.4301 and heater element in stainless steel EN 1.4301. Complete with built-in heater in the junction box. Heater elements are mounted in a removable cassette.

Marking: Ex II 2 G Ex eb db mb IIC T3 Gb

Air flow: 7000 m<sup>3</sup>/h.

Dimension width: 1200 mm

Dimension height: 500 mm

Dimension depth: VEAB will specify the depth in the quote and in the order confirmation

Output: 80 kW

Output steps: 40 kW+ 40 kW

Voltage: 3x400V

Model: M

Casing material: Stainless steel, EN 1.4301

Degree of protection: IP66

Temperature class: T3 (max 200°C)

Max output air temperature: 40°C

Element material: EN 1.4301

Heater in junction box: Yes

### Descriptive text - VTL2-Ex

ATEX-approved duct heater of VEAB type VTL2-Ex-1200x500-80kW-3x400V-M-S-IP66-T3-40C, with casing in stainless steel EN 1.4301 and heater element in stainless steel EN 1.4301. Complete with built-in heater in the junction box.

Marking: Ex II 2 G Ex eb db mb IIC T3 Gb

Air flow: 7000 m<sup>3</sup>/h.

Dimension width: 1200 mm

Dimension height: 500 mm

Dimension depth: VEAB will specify the depth in the quote and in the order confirmation

Output: 80 kW

Output steps: 40 kW+ 40 kW

Voltage: 3x400V

Model: M

Casing material: Stainless steel, EN 1.4301

Degree of protection: IP66

Temperature class: T3 (max 200°C)

Max output air temperature: 40°C

Element material: EN 1.4301

Heater in junction box: Yes

### Descriptive text - VRA2-Ex

ATEX-approved duct heater of VEAB type VRA2-Ex-1200x500-80kW-3x400V-M-S-IP66-T3-40C, with casing in stainless steel EN 1.4301 and heater element in stainless steel EN 1.4301. Complete with built-in heater in the junction box.

Marking: Ex II 2 G Ex eb db mb IIC T3 Gb

Air flow: 7000 m<sup>3</sup>/h.

Dimension width: 1200 mm

Dimension height: 500 mm

Dimension depth: VEAB will specify the depth in the quote and in the order confirmation

Output: 80 kW

Output steps: 40 kW+ 40 kW

Voltage: 3x400V

Model: M

Casing material: Stainless steel, EN 1.4301

Degree of protection: IP66

Temperature class: T3 (max 200°C)

Max output air temperature: 40°C

Element material: EN 1.4301

Heater in junction box: Yes



Wiring diagram

Example connection 1  
230V~ and 400V2~

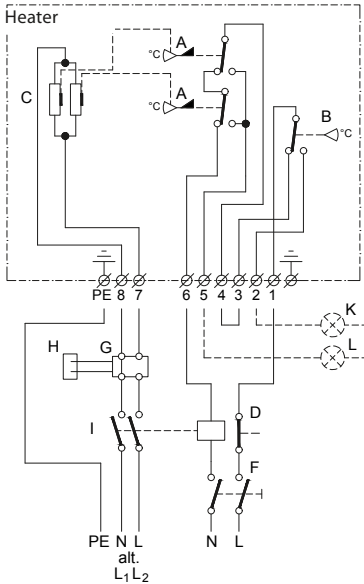

Example connection 2  
Max 43 kW, 400V3~ (63A)

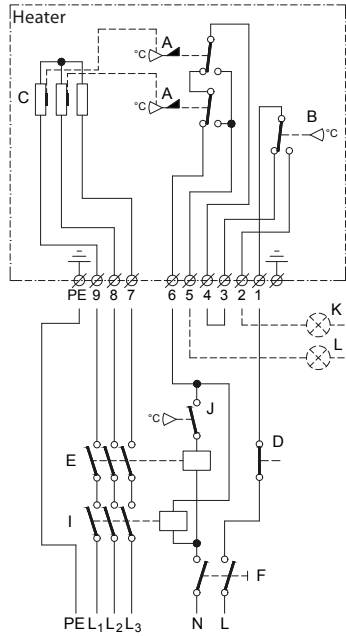

Example connection 3  
Max 43 kW, 400V3~ (63A)  
with heater in junction box

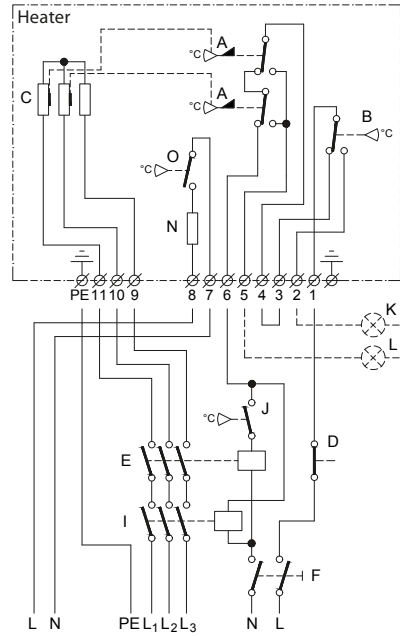

Example connection 4  
Max 129 kW, 400V3~, 3 power steps (1/3+1/3+1/3)

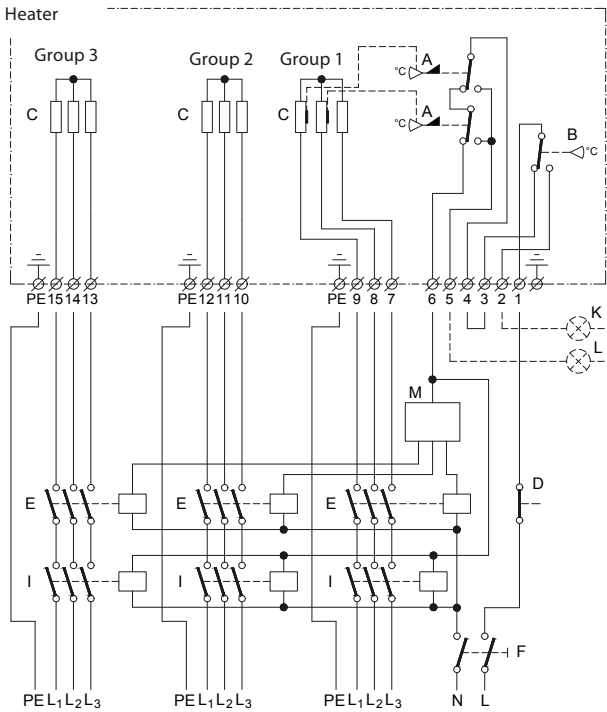

Inkopplings exempel 5 / Wiring example 5 with thyristor regulation.  
Max. 129kW, 400V3~, 3 groups (1/3+1/3+1/3)

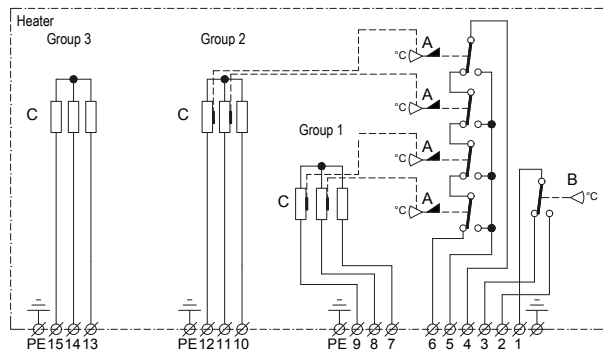

- A 2 temperature limiter with manual reset, monitoring surface temperature.  
Fitted on the heating elements in power step 1
- B Temperature limiter with automatic reset, limiting outgoing air temperature.
- C Load
- D Interlocking
- E Contactor
- F All-pole switch
- G Output control
- H Sensor
- I Safety contactor
- J Thyristor
- K Signal, high temperature output
- L Signal, tripped overheating cut-outs
- M Controller
- N Thermostat regulation
- O Heater in junction box, 50W





**VEAB Heat Tech AB**  
Phone: +46(0)451-485 00 • Fax: +46(0)451-410 80  
[www.veab.com](http://www.veab.com) • [veab@veab.com](mailto:veab@veab.com)  
Sweden